



# PP30 Operation Manual

---



*PP30 Cogeneration System*

# Table of Contents

---

<b>1. Technology Foundations</b>	<b>3</b>
<b>2. Power Pallet Crate Contents</b>	<b>6</b>
<b>3. Safety Procedures</b>	<b>7</b>
<b>4. Required Tools</b>	<b>8</b>
O&M Tool List (Required)	8
Technician Tool List (Nice to Have)	9
<b>5. Power Pallet Set Up</b>	<b>10</b>
5.1. Facility Requirements	10
5.2. Connecting to Loads	12
5.3. Connecting to the Grid	12
<b>6. Feedstock Requirements</b>	<b>13</b>
<b>7. Operating Procedures</b>	<b>16</b>
7.1. PP30 Engine Pre-Start Duties	16
7.2. PP30 Gasifier Prestart Duties	22
7.3. PP30 Gasifier-Engine Startup	30
7.4. PP30 Shutdown	33
7.5. Refilling the PP30	36
<b>8. Maintenance Schedule</b>	<b>37</b>
<b>9. Spare Parts</b>	<b>39</b>
<b>10. Service Record Form</b>	<b>40</b>

# 1. Technology Foundations

---

## Gasifier Supersystem (gasifier Module)

- The gasifier system

## Power Generation Supersystem

- Power generation system

## Combined Supersystem

- Power generation supersystem
- The gasifier supersystem





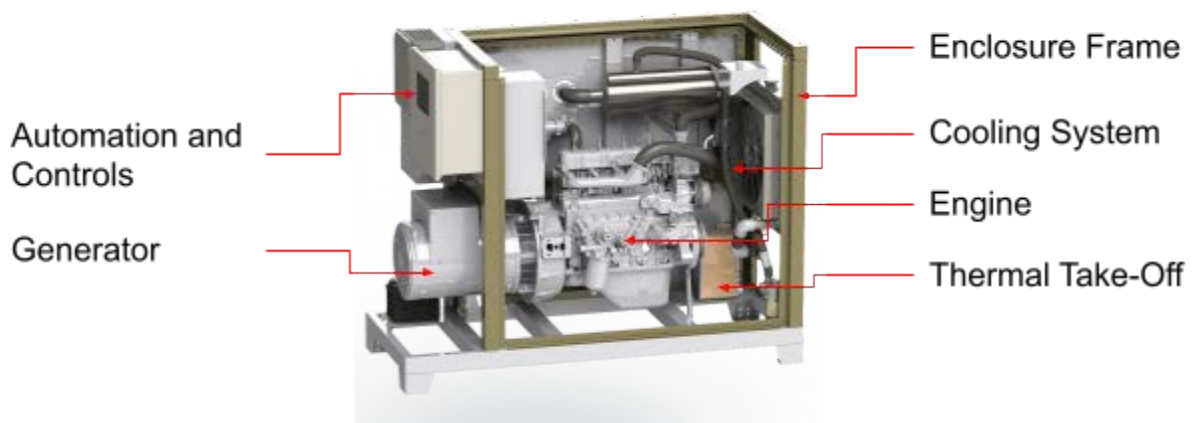
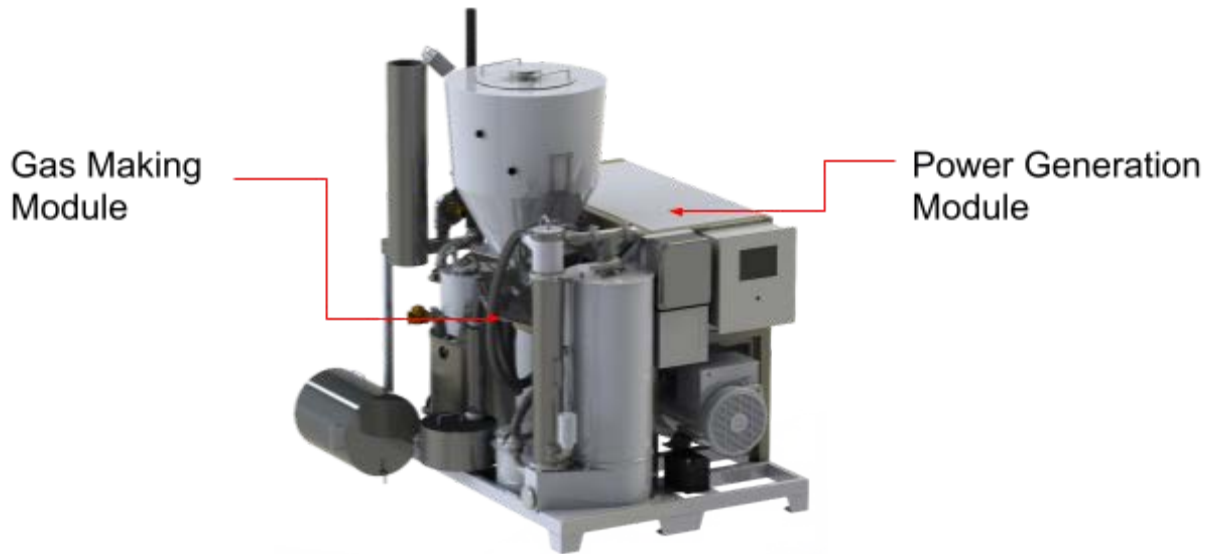

## 2. Power Pallet Crate Contents

---

1. Power Pallet Gasifier System
2. Power Pallet Generator System
3. Charcoal for first start of reactor
4. CO Monitor
5. Basic Tool Assortment
6. Set of Essential Spares
7. Miscellaneous supplies for maintenance operations

### 3. Safety Procedures

---



**CAUTION:** Operator must wear personal protective equipment when operating this machinery.

- Whenever filling or emptying feedstock or char a mask appropriate to protect against fine particulates must be worn.
- Read all instructions and documentation carefully before operating or servicing.



- Service or operate only in a well ventilated area.
- All vessels contain high concentrations of toxic Carbon Monoxide (CO) gas even when cool.
- Keep supplied CO alarm nearby when operating or servicing.
- Do not service until machine has been purged as described in section 7.3 of this manual.
- Do not service while machine is in operation.
- Allow reactor to cool to room temperature before servicing.

# 4. Required Tools

---

## O&M Tool List (Required)

The following tools are required to perform regular Power Pallet O&M activities.

- Gas line wire brush
- 7mm wrenches
- 8mm wrenches
- 1/2" sockets and wrenches
- 9/16" sockets and wrenches
- 7/16" deep sockets
- 3/4" wrenches
- 7/8" wrenches
- 9/64" Allen/hex wrench
- Allen/hex wrenches various sizes
- Crescent wrenches various sizes
- Phillips screwdriver various sizes
- Flathead screwdriver various sizes
- Scissors
- Sharpies or permanent marker alternative
- Blue paper tape
- Electrical tape
- Propane Torch
- Teflon pipe tape
- Denatured alcohol
- Paper towels
- Graphite paste
- 1/8" graphite rope
- 3/8" graphite rope
- Windows Computer
- Scale for measuring weight of fuel
- 1/2" pipe tee for lighting
- 12' ladder
- 6x ~30 gal trash cans or equivalent for fuel loading
- 2x - 3x Carbon Monoxide Sensor
- ABC Fire extinguisher
- Water Hose
- Fork lift
- Big Wipes Heavy Duty Textured Scrubbing Wipes



## Technician Tool List (Nice to Have)

The following tools will allow more complex Power Pallet O&M activities.

- Pliers
- Needle nose pliers
- Wire strippers
- Crimpers (ABCDE kind)
- Wire cutters
- Timing Light
- Voltmeter
- Cables/dongles for connecting computer to PP to load firmware
- Firmware
- Configuration tools
- DSE Software
- Tunerstudio Software for MS3 Pro

# 5. Power Pallet Set Up

---

## 5.1. Facility Requirements

The facility to house the power pallet must have the following characteristics:

- Level flooring made of non-flammable material capable of supporting the weight of the machine (listed in the Specifications section).
- Facility must have a covered location to protect the power pallet from direct rain or water, as some aspects of the system are not water/weather resistant.
- The system is to be installed with a 92 cm clearance around the footprint of the machine and at least a 173 cm clearance above the machine. See illustration on the next page.
- Sufficient ventilation through an exhaust hood with air flow capacity adhering to local regulations.
- Install the CO meter provided with the power pallet and verify that it functions properly. Have a CO meter near the operating floor at all times even when the machine is not in operation and especially when performing maintenance.
- Operate the power pallet in locations having a max temperature of 40 °C and at an altitude of 1000m or less. The power pallet's power output will be derated at higher altitudes. In case of different conditions, please consult ALL Power Labs.
- Install the PP30 out of direct sunlight. UV from sunlight will damage parts over time.



## **5.2. Connecting to Loads**

- Hook up the cam lock connections to an off load system you want to send power to that is within the power pallet electricity load range. (5-25 kW)
- Press Close Generator button to close the contactor and start sending power to an external load.

## **5.3. Connecting to the Grid**

- Connect cam locks to interconnection point with grid.
- Press Close Generator button to close the contactor and start generator synchronization process with the grid. If generator does not synchronize, please look at technician manual for troubleshooting steps.

# 6. Feedstock Requirements

For your gasifier to operate properly, you must use the correct biomass feedstocks which have been properly prepared and sifted. Certain material shapes and sizes flow better in solid material handling systems. For example, long stringy pieces, similar to toothpicks, do not flow well, as they get stuck in feeds. Materials in circular shapes such as walnut shells or macadamia nut shells flow well.

Feedstock biomass must be dry, of the correct shape and size to flow through the reactor, and free of dust, sand and contaminants:

- Particle size: 1 cm – 4 cm (0.5 in. – 1.5 in.)
- Moisture content (% by dry weight): 5% – 30%
- Ash content <5%



The following Table of Feedstocks shows the most common ones that have been tested and are known to work, which ones are known to be unusable, and which ones need more testing. For more information on fuel preparation, contact APL For more information on fuel preparation, contact [APL](#).

LEGEND	
Green	Known to work with standard operations and maintenance effort
Yellow	Known to work with increased operations and maintenance effort
Grey	Not enough testing to approve at this time. Use voids warranty
Red	Known to not work. Use voids warranty.

Feedstock	Notes
Wood Chips (e.g: Oak, Rubber, Pine)	Use only chips; chunks or long shards can bind auger or bridge in the reactor
Nut Shells (e.g: Coconut, Walnut, Hazelnut)	Not all shells will work, please contact us to discuss your particular feedstock
Corn Cobs	Must be broken to size and must not include husks. Increased chance of slagging
Palm Kernel Shells	Risk of high temperatures. May need to be blended or other steps taken to lower temperatures
Macadamia Nut Shells	Excellent shape, not enough testing
Cashew Nut Shells	Known toxicity, not enough testing
Wood Pellets	May work depending on size & makeup, pellets prone to decompose
Coffee Grounds	Too fine for physical compatibility, pelletization may allow use
Saw Dust	Too fine for physical compatibility, pelletization may allow use
Corn stover	High ash content; silica content leads to slag
Rice Husk	High silica content leads to slagging
Bamboo	Difficult to prepare to correct size and shape
Grasses: Switchgrass, Miscanthus, etc.	High silica and low bulk density.
Paper, Sugarcane Bagasse, Coconut Husk	Shapes not physically compatible

Municipal Solid Waste/Trash	Slag risk; heavy metals; plastic content not suitable
Coal	Burns too hot, releases sulfur and heavy metals
Plastics	Melts and fouls auger/reactor
Manure: Cow, Pig, Chicken, etc	High slag, low energy density
Tires	Not chemically compatible

# 7. Operating Procedures

---

The following procedures assume that the Power Pallet has been assembled and installed correctly. Training by a certified APL trainer is recommended before operating the PP30 for the first time. For a list of all parts of the Power Pallet including a list of parts, definitions and all other useful information see the **PP30 Component Reference** document.

---

## 7.1. PP30 Engine Pre-Start Duties

### Power Generation Supersystem

1. Check DC battery voltage is over 12V (DSE->Engine->Battery Voltage)
  - a. Turn the the Power Pallet on by flipping the power switch up (Image 1)



**Image 1**

- b. Starting from the **Status** screen press right arrow one time to get to the screen to **Engine** screen (Image Set 2)
    - c. Then press down arrow 4 times to get to **Engine Battery Voltage** screen
    - d. If voltage is under 12V, connect and power on-board or external battery charger

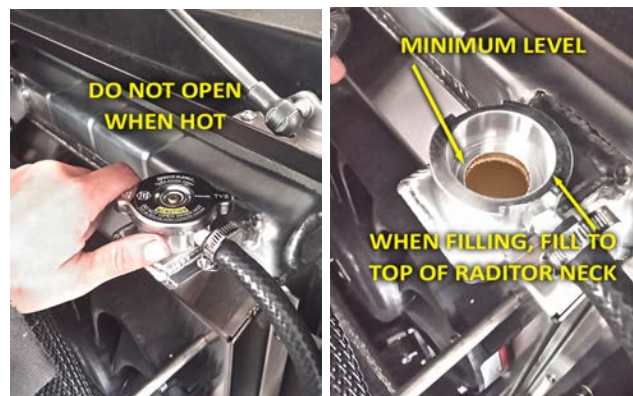



**Image Set 2**

2. Check radiator coolant level and refill if needed (see *PP30 Engine Check for fill instructions*)

**WARNING:** Do not open the radiator cap when the unit is hot



**Image Set 3**

3. Check expansion tank fluid and refill if necessary (Image Set 4)
  - a. Fluid should reach the **Normal line** indicated in the picture
    - i. if it is below this line, fill up to the line

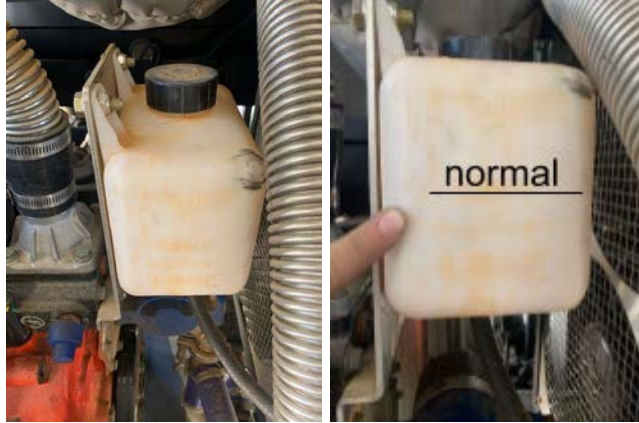

**Image Set 4**

4. Check engine oil level and refill if necessary (See *PP30 Engine Check for fill instructions*)
  - a. Pull the dipstick and clean it. Reinsert and pull it again and then check to see if the oil is between the marking on the dipstick
  - b. If the oil level is low, add oil according to SOP

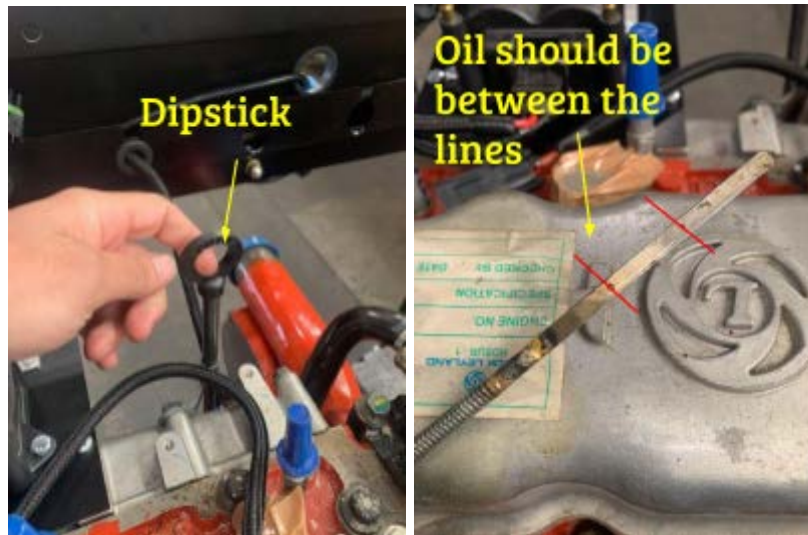

**Image Set 5**

5. Check Governor (Image Set 6)
  - a. Unplug the governor
  - b. Remove sanitary clamps and gaskets

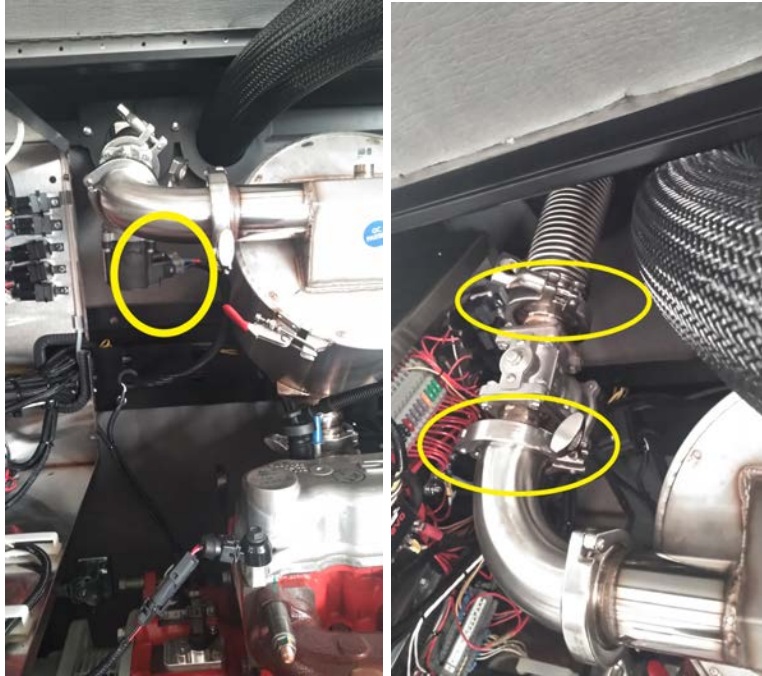

**Image Set 6**

- c. Physically check if the governor throttle plate moves freely (Image 7)
  - i. When pressed all the way open the throttle plate should close all the way on its own with a snappy motion

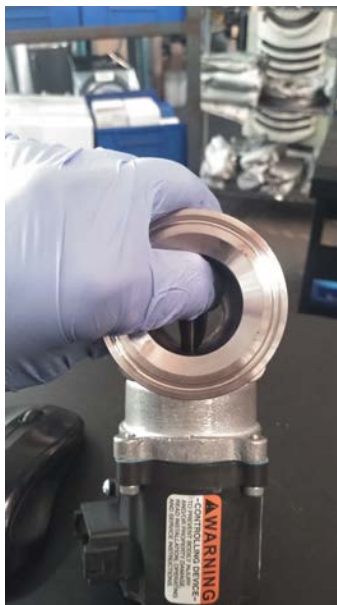

**Image 7**

- d. If check fails, clean governor (see *PP30 Engine Check for cleaning instructions*)
- e. Re-install governor using sanitary gaskets and clamps and plug back in

- i. Make sure to clean gaskets of tar and dirt before installation by wiping them with a paper towel
- ii. Ensure that the governor plug is facing downwards when you install it



**Image Set 8**

6. Check Polishing filter (Image 9)
  - a. Remove V-band clamp and sanitary clamp from lid and pull out the polishing filter  
Pliers can help with the removal of the filter element



**Image Set 9**

- b. Remove and inspect filter element (Image Set 10)
  - i. **Inspection fails** if the polishing filter
    1. Appears dark black with no yellow on the far said
    2. Is noticeably wet

3. You can not see sunlight through the element when pointed at the sun



**Image Set 10**

- c. If inspection fails - Replace with new filter. Record in *Daily Operation Records*.
- d. Remove the metal mesh flame arrester from the bottom of the filter canister and check to see if it is dirty - it is dirty if it is covered in tar or soot and if you cannot see through it (Image 11)

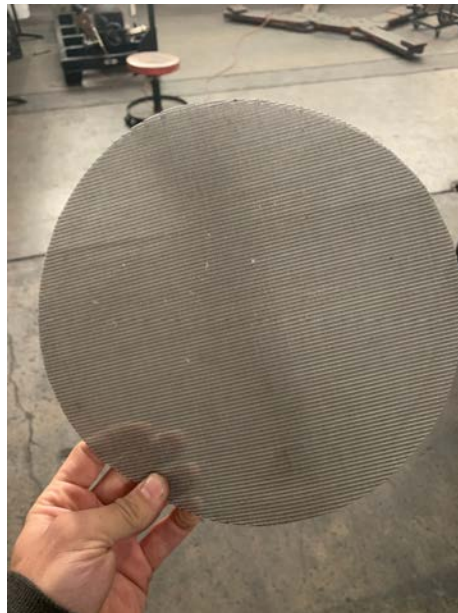

### Image 11

- i. Clean if necessary with alcohol
    - e. Replace the flame arrestor, filter, and lid. Secure with V-band and sanitary clamps
  7. Check and tighten any additional engine gas connections, bolts and sanitary clamps that were removed during this process.
- 

## 7.2. PP30 Gasifier Prestart Duties

### Gas Making Supersystem

1. Manually check the air inlet swing-check valve on side of pyroreactor for free movement
  - a. Remove the plug that is screwed onto the air inlet swing-check valve and push the swing-check valve with your finger to check if it swings freely (Image 2).
    - i. If stuck, use a suitable tool such as the back end of a wrench to knock it loose and then assure that it swings freely.
      1. Hitting the brass valve will not damage it
    - ii. If it does not, clean it by spraying it with alcohol while manually moving the flapper. Wear gloves during this procedure
  - b. Reinstall the plug



Image 1

2. Empty the “Ash Collection Vessel” (ACV) following site procedures (Image 2)
  - a. **CAUTION** Before opening up the ACV make sure that the area is well ventilated and are wearing proper PPE
  - b. Remove the sanitary clamp holding the ACV to the unit
  - c. Empty the can into its appropriate receptacle
  - d. Record data according to the site procedures
  - e. Replace the ACV onto the unit, and secure it with the sanitary clamp
3. Empty the “Cyclone Collection Can” (CCC) following site procedures. (Image 2)
  - a. **CAUTION** Before opening up the CCC make sure that the area is well ventilated and are wearing proper PPE
  - b. Remove the sanitary clamp holding the CCC to the unit
  - c. Empty the can into its appropriate receptacle
  - d. Replace the CCC onto the unit, and secure it with the sanitary clamp



**Image 2**

4. Ensure that the hopper is filled with feedstock either manually or with the Continuous Feed system (refer to feedstock specifications in your manual for more information)
  - a. **NOTICE:** when starting the Power Pallet for the first time or after maintenance that removed the charcoal has been performed, fill the reactor with charcoal until it reaches the tip of the feedstock switch. If there is not enough charcoal

provided, use locally sourced charcoal (e.g. sifted ACV char). The correct size of the charcoal to use to fill the reactor is roughly that of the charcoal produced from the ACV. APL provides an initial bag of the correct size for starting the power pallet the first time.

5. Check that the CO detector works by pressing the test button, and listening for the beep
6. Turn on the automation assembly by flipping the power switch (Image Set 3)



Image Set 3

7. Record data per site operating procedures.
8. Check functionality of ash auger and grate shaker from PCU control (Image Set 4)
  - a. Grate shaker check
    - i. Press next once from the status screen to get to **manual controls**





#### Image Set 4

- ii. Press adv once to advance from *fuel auger* to *grate shaker* (Image 5)



Image 5

- iii. Press mode twice to change from *auto* to *on* (Image 6)



Image 6

- iv. Run for a few seconds, listen for the shaker functioning and then press

mode once so display reads auto (Image 6)



**Image 7**

- b. Ash auger function test
  - i. Ensure status screen is on *manual control* (Image Set 8)



**Image Set 8**

- ii. Press adv twice to advance from *fuel auger* to *ash auger* (Image 9)



**Image 9**

- iii. Press mode twice to change from *auto* to *on* (Image 10)



**Image 10**

- iv. Leave on for one minute, visually confirm rotation by going around the back of the Power Pallet and looking at the gears that turn the ash auger, they are attached to the bottom of the cowling near the Reactor Access Door (Image 11)



**Image 11**

- v. Then press mode twice so display reads **auto**
- vi. Return to the status screen by pressing next

9. Perform a Leak Down test (this is a test where we determine if there is an air leak in the system) (Image Set 12)
  - a. Open the flare valve by turning it until it is vertical and close the valve to the engine by turning it horizontally
  - b. Ensure that the air inlet plug is tight
  - c. Turn the gas blower up to 11 (the maximum setting) to apply vacuum to the entire gas circuit
  - d. Check if Test Criteria #1 is passed
  - e. Shut the flare valve, then turn off the blower. The valve should lock in the vacuum pressure
  - f. Check if Test Criteria #2 is passed

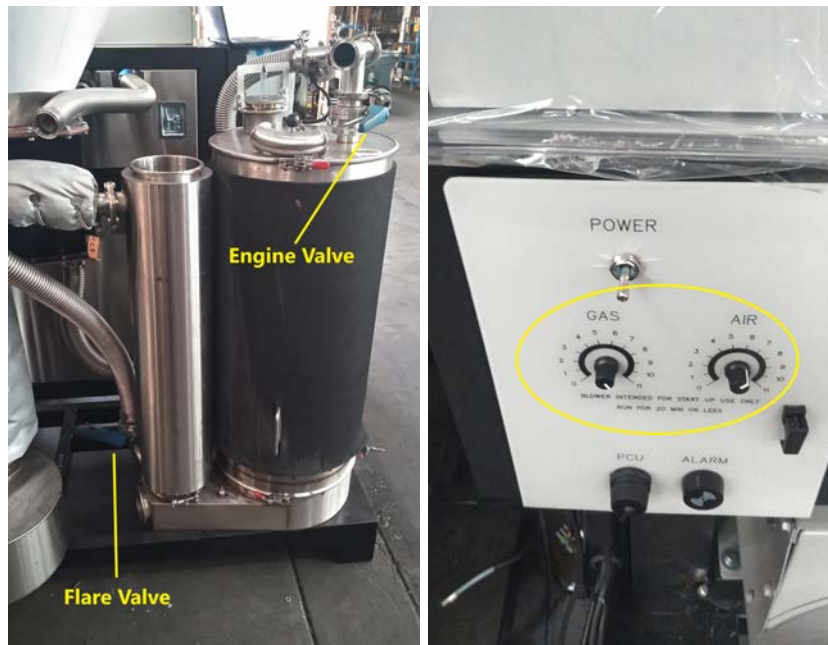

**Image Set 12**

**Test criteria #1:** When the numbers indicated for **Preac** and **Pcomb** on the PCU stop rising:

- **If the reactor pressure reading is near or >90**, the reactor passes the first leak test
- **If the pressure is <90, the test fails.** It may be that the battery has insufficient charge, there is a significant leak, blowers need to be checked, or there is a large pressure drop in the system. This needs to be solved before continuing. See (troubleshooting doc)

**Test criteria #2:** After closing the flare valve, the pressure will begin to drop. Immediately after the valve is closed, start timing. Watch as the pressure drops on the PCU (seconds in the lower right corner)

- **Takes >30s to reach 0.** This is typical for new and well sealed systems. The reactor passes the leak test
- **If the pressure drops to zero <30 sec**, the reactor fails, and should not be operated until the leak is repaired. This time can be counted, or monitored with the timer in the bottom right of the PCU

If the test fails, check, clean, grease and tighten all gasifier gas connections, bolts, and sanitary clamps, anywhere where air could leak into the system. See [Troubleshooting](#) document for more information on repairing and finding air leaks.

### 7.3. PP30 Gasifier-Engine Startup

#### Collect the following items:

1. ½" NPT Pipe tee for lighting port
2. Sifted ACV Charcoal
  - a. Sift ACV using a screen (wear proper PPE)
3. Propane torch
4. Small Pipe wrench
5. Heat protective gloves
6. Ear and eye protection

#### Gas-Making Supersystem

**CAUTION** Before starting up the Power Pallet sure that you are in a well ventilated area and are wearing proper PPE

1. Ensure power is on (Image Set 1)
2. Remove cap from lighting port
3. Attach pipe tee to lighting port, a single turn is enough
4. Place a few grams of ACV charcoal in pipe tee
5. Close both flare & engine valve by turning to horizontal and turn gas up to 11 (Image 2)



**Image Set 1**



**Image 2**

6. Using a propane torch, light the ACV char in pipe tee (Image Set 3)
7. When char is glowing, slowly open the flare valve, letting the embers be sucked into the reactor
8. If any charcoal is stuck in the tree, light it if not glowing, and poke it into the reactor



**Image Set 3**

9. When the top of the flare stack starts to smoke (should take a several minutes depending on feedstock and weather conditions) the producer gas should ignite
10. If the flare stack does not smoke, and Trst on the PCU screen does not start to climb, repeat steps 4-7. If Trst is climbing, and no smoke is seen, check that the flare valve is open, and that Preac is a negative number
11. If Trst is slow to climb, the grate shaker can be activated to speed the process up
12. Once ignited, turn the air to 5. A loud roaring sound indicates that the PP is flaring properly
13. Remove air intake plug (with wrench if needed)
14. Wearing heat resistant gloves, remove the pipe tee and reinstall the ½" NPT cap on the lighting port and tighten lightly with the pipe wrench
15. Increase the air blower to 7 and continue to adjust to maintain a strong roaring sound from the flare to allow the reactor to reach full operating temperature. This can take 10-15 minutes
16. Once Trst (PCU - temperature at the restriction zone) is greater than 750°C and Tred (PCU - temperature at the reduction zone) is greater than 300°C, the engine can be started using the following steps (note: while the engine can be started at lower values, the PP30 system will accumulate more tar and require more maintenance)

### **Power Generation Supersystem**

1. Turn both the gas and air down to 0, close the flare valve, and open the engine valve (turn it vertically)
2. On the generator controller, press **Stop/Reset**, then **Manual Mode**, then **Start** button to start the engine
3. The status screen will confirm that the engine is running and count down timers will



elapse for about 1 minute. If the engine does not start, repeat the process up to 3 times. See *Troubleshooting* if engine still does not start

4. Once the engine has warmed up, the 'Generator Available' light (listed as 2 on the Four Configurable status LEDs table below) will turn on. Press the **Close Generator Button** to close the connection to the generator and export power/energize load



Image 5

### Four Configurable status LEDs

1	Bus Live
2	Generator Available
3	Contactor Closed
4	Power Export

---

## 7.4. PP30 Shutdown

1. Turn off all devices connected to the generator
  - a. If running a load bank or other incremental loads, slowly remove the load step by step
2. Disconnect Generator from the devices via the button on the top left (**Open Generator Button**) (Image 1)
3. Press the red button (**Stop/Reset Mode Button**) to turn off the engine (Image 1)

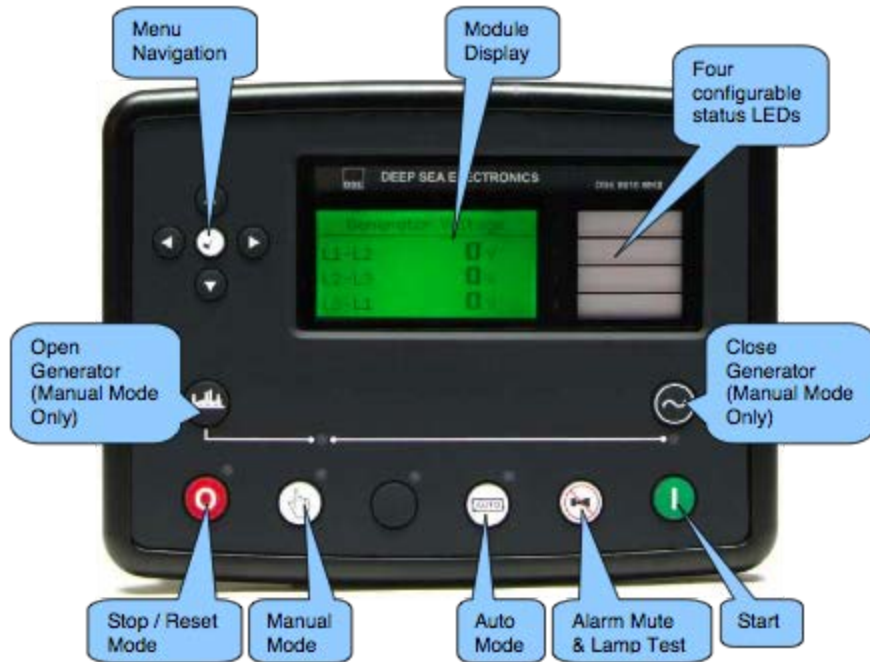

**Image 1**

4. Put the PP30 in cool-down flaring mode (Image Set 2)
  - a. Close the engine valve and open the flare valve
  - b. Turn both the gas and air blowers to 6. Let the PP flare for 2 mins
  - c. Cap the air intake valve with the 2" plug
    - i. Turn the gas to 0, and leave the air on
  - d. Wait an additional 10 minutes for the unit to cool
5. Close flare valve
6. Turn the power off on the PP30 automation assembly



**Image Set 2**

7. Return all PPE and documentation to the proper storage location
8. If the unit will not be used for longer than two weeks, remove the negative battery leads from the battery.

---

## 7.5. Refilling the PP30

### Recommended hopper fill schedule

Fuel type	kW	Time between refills	Amount to fill each refill
Walnuts	15	2.5 hrs	100 L
	20	2 hrs	100 L
	25	1.5 hrs	100 L
Woodchips	15	1.5 hrs	100 L
	20	1 hrs	100 L
	25	.5 hrs	100 L

### Refilling Procedure

1	Check to make sure the feedstock to run the pallet is staged for the day and weighed into their respective loading containers (bags, buckets, etc)
2	Make sure there is a safe means to refill the hopper, either using a ladder, stairs, etc. If using a containerized system, use a safe means to get to the top of the container.
3	Make sure you have a respirator, preferably 3M type with 60926 cartridges, and earmuffs. This PPE must be worn when refueling power pallet systems.
4	Make sure the load is less than 15 kW when refueling. If it is not less than 15 kW, lower the load while refueling and it can be turned up after.
5	Once you are ready to load the hopper, safely access the top of the unit and twist counterclockwise to remove the hopper lid. If using a containerized system, this will be through the top hole in the container where the hopper can be seen.
6	Top off the hopper with feedstock.
7	Close the hopper lid securely.
8	Record the amount of feedstock loaded. (note: this can also be planned by recording staged containers before refilling the unit)

## 8. Maintenance Schedule

---

100 hours	Clean cyclone insides from base with scraping bar
100 hours	Check/replace filter gaskets
125 Hours	Check/replace reactor access door graphite paste
125 Hours	Check/replace cyclone collection can gasket
125 Hours	Check/Calibrate O2 sensor
125 Hours	Clean air intake check valve
125 Hours	Clean cyclone to producer gas heat exchanger gas line
125 Hours	Fill ash auger tube with grease
125 Hours	Fill grate shake tube with grease
125 Hours	Remove soot build up from airlines (reactor burnout)
125 Hours	Review various alarms and fixes performed
200 hours	Check/clean/replace governor bearings
200 hours	Check/clean/replace gas blower
250 hours	Check/replace cyclone sani gasket
250 hours	Check/replace: 4" OD PTFE sani gasket for pyroreactor view port
250 hours	Check/replace: 2" OD PTFE sani gasket for ACV connector
250 hours	Calibrate pressure sensors
250 hours	Check/clean spark plugs
250 hours	Clean out/inspect inside of pyroreactor and hearth surface
250 hours	Clean/inspect pyroreactor grate basket and purge clinkers
250 hours	Check/tighten grate shaker gears and shaft collar nuts and bolts
250 hours	Check/tighten feedstock auger shaft collar and drying bucket connection
500 hours	Check/replace: graphite paste (PYR> CYC)

500 hours	Check/replace: graphite paste (PYR> DRK)
500 hours	Replace engine coolant (12 qt fill)
500 hours	Replace Engine Oil
500 hours	Replace Ashok engine oil filter
500 hours	Check/replace: 4" OD PTFE sani gasket for ACV clean out port
500 hours	Check/Clean Battery Terminals
500 hours	Filtration tune up
700 hours	Check/Replace Pyroreactor
1000 hours	Check/Replace gas cowling assembly
1000 hours	Flush radiator
1750 hours	Pyroreactor overhaul
1750 hours	Flare maintenance
1750 hours	Airlock maintenance
1750 hours	Engine tune up
3500 hours	Gas cowling overhaul
3500 hours	Automation maintenance
3500 hours	Engine head rebuild
7000 hours	Airlock overhaul
7000 hours	Full engine rebuild

\*Subcomponent documentation for Ashok Engine: [maintenance schedule \(starting page 75\)](#)

\*See individual Standard Operating Procedure (SOP) documents for specific parts, processes, and specifications.

# 9. Spare Parts

---

APL has provided the following spare parts to minimize equipment downtime.

## PP30 Spare Parts List: 0–500 hrs

- 4× spare gas blowers
- White lithium grease
- 2× spare spring check valve springs
- 1× spare O<sub>2</sub> sensor
- Graphite paste
- Graphite rope
- 1× spare 2" sani-gaskets

## PP30 Spare Parts List: 500–1000 hrs

- Engine oil
- Ashok engine oil filter
- 4× 4" sani-gaskets
- Antifreeze

## PP30 Miscellaneous Spare Parts

- 2× 2" sani caps
- 4× 2" sani gaskets
- 4× 2" sani clamps
- 1× 4" sani caps
- 2× 4" sani gaskets
- 1× 4" sani clamps
- 1× 6" sani caps
- 2× 6" sani gaskets
- 1× 6" sani clamps
- 1× Thermocouple
- 1× Thermocouple Compression Fitting
- 1× Thermocouple extensions
- 2× Exhaust and muffler clamps (2" V-band Clamp)
- 20' Pressure lines
- 4× spark plugs
- 1× set Spark plug cables







## PP30 Operation Manual

DOCUMENT INFORMATION	
DOCUMENT NO:	FILE-004209
REVISION:	07
DATE RELEASED:	02/23/2023
CATEGORY:	Procedure

REVISION HISTORY			
Revision	Description	Date	Author
03	Updated text information, images, forms and necessary details pertaining to PP30 Operation Manual.	06/13/2019	Alejandro
04	Updated text information and necessary details pertaining to PP30 Operation Manual.-	06/28/2019	Juan M. Aceves
05	Replaced PP30 photos with newest images	10/18/19	Nesdon Booth
06	Corrected Text in startup procedure	5/4/20	Eli Whipple
07	Addressed some unresolved comments & included content from separate SOP docs	2/23/22	Nesdon Booth